

Technical Specifications

MobileMAX 2 MobileMAX 3

Airflow	Industry standard (cfm)	6,500	8,500
Cooling capacity*	0.3 IWG (BTU/hr)	28,800	42,000
Power consumption (total)	Watts max / min	990	1300
	Current max (amp)	8.7	11.3
Power supply	Voltage / Phases / Hz	115 / 1 / 60	115 / 1 / 60
Controller	Type	2-Speed	2-Speed
Fan	Type	Centrifugal	Centrifugal
	Dia x width (inches)	15 x 15	18½ x 15
V-Belt	4L / A	A50 / 4L-520	A55 / 4L-570
Motor	Type	PSC-2 Speed	PSC-2 Speed
	Rating (watts)	550	750
	Overload	Auto	Auto
	Enclosure	IP21	IP21
Pump	Type	Centrifugal	Centrifugal
	Motor	Synchronous	Synchronous
	Rating Watts (input)	30	30
	Flow rate (gal/min)	51 @ 3.9ft head	51 @ 3.9ft head
	Voltage / Phases / Hz	115 / 1 / 60	115 / 1 / 60
	Overload	Auto reset	Auto reset
	Enclosure rating	IP X4	IP X4
Cooling pad	Size (inches)	31½ x 22½ x 2	31½ x 34½ x 2
	Pad area (ft²)	14.8	22.5
Water	Tank capacity (gal)	26	26
	Inlet (inches)	¾ FH x ½ FIP	¾ FH x ½ FIP
Shipping	Dimensions excluding pallet (inches)	40 x 40 x 42 (add 5" height for shipping pallet)	40 x 40 x 54 (add 5" height for shipping pallet)
	Volume (ft³)	51	64.5
	Mass (lbs)	245	265
	Operating (lbs)	188	210

*This cooler has been tested in accordance with the requirements of the California Energy Commission Appliance Efficiency Regulations, Section 1603 and 1604.

Cooler Discharge Air Temperature Chart

		Ambient Relative Humidity %								
		10	20	30	40	50	60	70	80	90
Ambient Dry Bulb Temperature °F	50	36.2	37.9	39.6	41.2	42.8	44.3	45.8	47.2	48.7
	60	42.9	45.1	47.2	49.3	51.3	53.2	55.0	56.7	58.4
	70	49.2	52.1	54.7	57.3	59.7	61.9	64.1	66.1	68.1
	80	55.3	58.9	62.2	65.2	68.1	70.7	73.3	75.6	77.8
	90	61.4	65.7	69.6	73.3	76.5	79.7	82.4	85.1	87.7
	100	67.2	72.5	77.1	81.3	85.1	88.5	91.7	N/A	N/A
	110	72.9	79.1	84.5	89.3	93.6	97.5	N/A	N/A	N/A
	120	78.7	86.0	92.2	97.5	N/A	N/A	N/A	N/A	N/A
	130	84.5	92.8	99.9	N/A	N/A	N/A	N/A	N/A	N/A

This chart represents approximate air temperatures based on 90% saturation efficiency at sea level. From tests carried out to Australian Standard 2913.

CABINET DETAILS

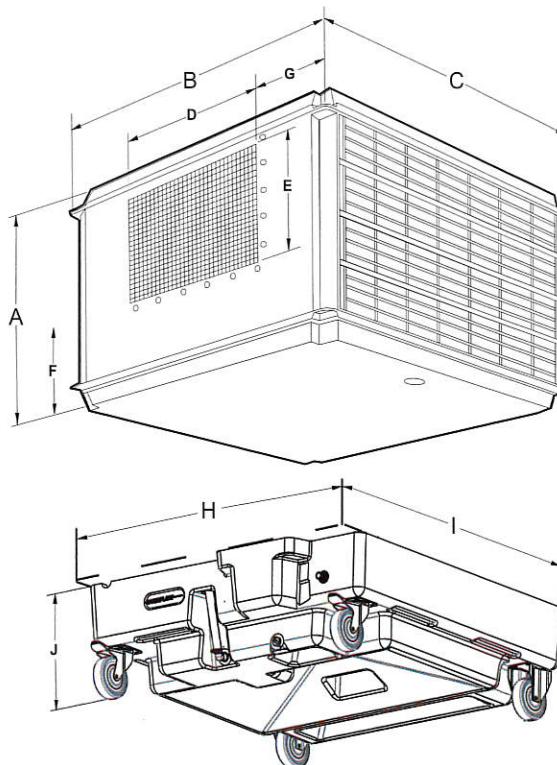

Model#	A	B	C	D	E	F	G	H	I	J
MobileMAX 2	30	39.5	37	19.5	14.5	11.5	10	40.16	40.75	15.58
MobileMAX 3	41.75	39.5	37	19.5	14.5	15.875	10	40.16	40.75	15.58

Note: All dimensions are in inches

FAN CURVES

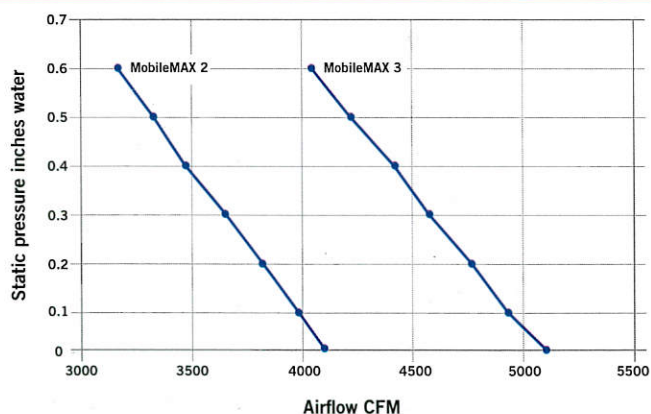

Model#	Industry STD Rating CFM	Motor H.P.	Certified Air Delivery (CFM) (static pressure inches water)							
			0.0	0.1	0.2	0.3	0.4	0.5	0.6	
MobileMAX 2	6,500	0.75	4100	3960	3810	3650	3480	3330	3160	
MobileMAX 3	8,500	1	5100	4920	4750	4570	4410	4230	4050	